



NAT050

MISTURADORA LAVATÓRIO ALTO NATURE

EN WASHBASIN HIGH MIXER NATURE

FR MÉLANGEUR LAVABO HAUT NATURE

ES MEZCLADOR LAVABO ALTO NATURE



A S M T A P S

WATER SOUL

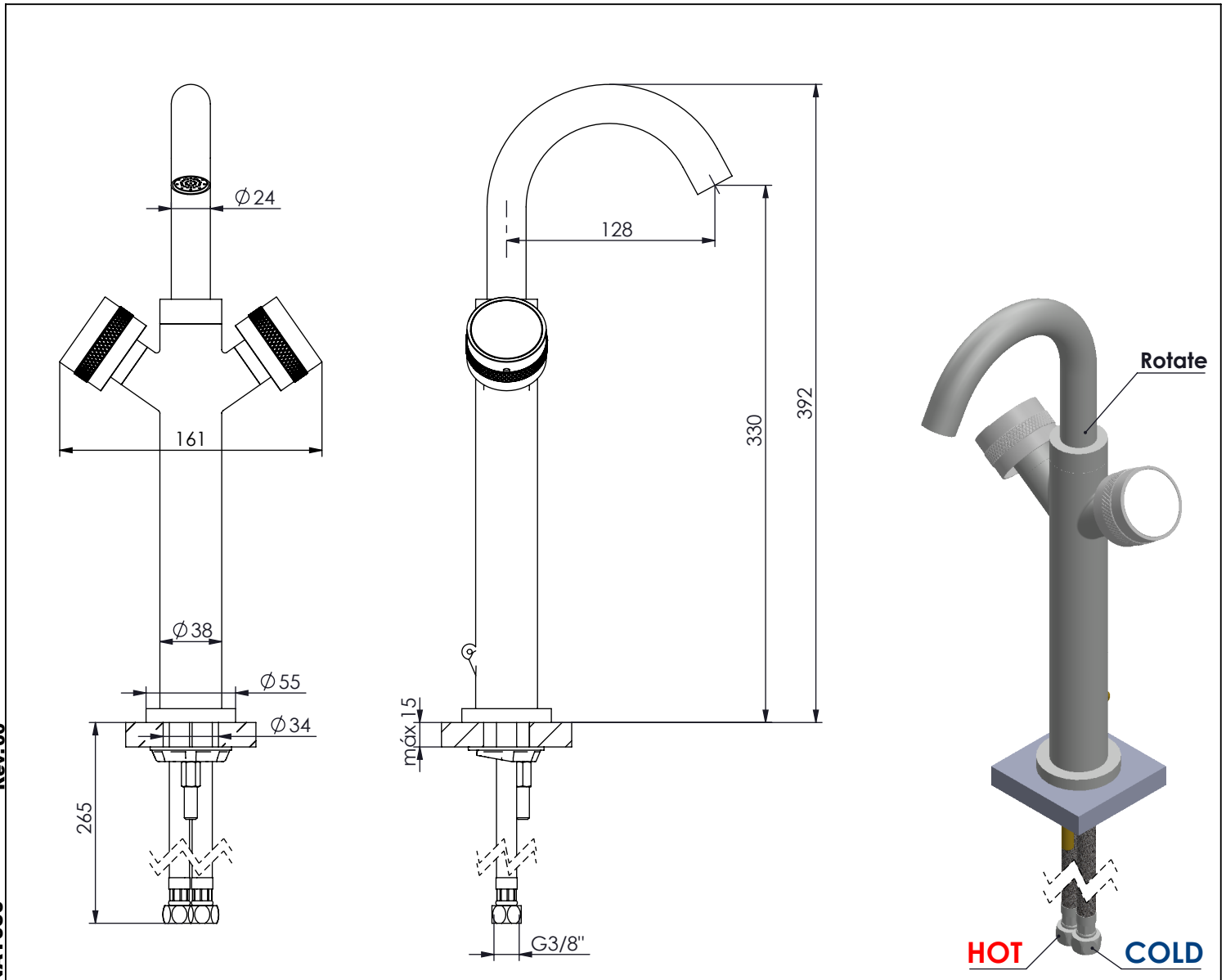

Rev.00

NAT050

CARACTERÍSTICAS TÉCNICAS

PRESSÃO RECOMENDADA:
RECOMMENDED PRESSURE: 3 - 4 BAR

TEMPERATURA RECOMENDADA:
RECOMMENDED TEMPERATURE: 15°C - 65°C

MATERIAIS:
MATERIALS: Latão

TEMPERATURA MÁXIMA:
MAXIMUM TEMPERATURE: 70°C

CAUDAL MÁXIMO A 3 BAR:
MAXIMUM FLOW AT 3 BAR: L/MIN

LIGAÇÃO DE ENTRADA:
INPUT CONNECTION: G3/8"

LIGAÇÃO DE SAÍDA:
OUTPUT CONNECTION: -

PESO (KG):
WEIGHT (KG): 1,75

DIMENSÕES EMBALAGEM (MM):
SIZE PACKAGING (MM): 367x250x80

ACABAMENTOS

CR - CROMADO | CHROME | CHROME | CROMO

PR - PRETO MATE | BLACK MATT | NOIR MAT | NEGRO MATE

BR - BRANCO MATE | WHITE MATT | BLANC MAT | BLANCO MATE

ST - SATINOX | SATINOX | SATINOX | SATINOX

AT - ANTRACITE | ANTHRACITE | ANTHRACITE | ANTRACITA

GM - GUNMETAL | GUNMETAL | GUNMETAL | GUNMETAL

GMM - GUNMETAL MATE | GUNMETAL MATT | GUNMETAL MAT | GUNMETAL MATE

OR - DOURADO | GOLD | DORÉ | DORADO

ORM - DOURADO MATE | GOLD MATT | DORÉ MAT | DORADO MATE

CB - COBRE | COPPER | CUIVRE | COBRE

CBM - COBRE MAT | COPPER MAT | CUIVRE MAT | COBRE MATE

TECNOLOGIA

 AC1360 - CASTELO CERÂMICO 1/2" 1/4 VOLTA
AC1360 - CERAMIC VALVE 1/2" 1/4 TURN