



NAT070B

MONOC. EMBUTIR LAVAT. PAREDE
ESPELHOS SEPARADOS Ø 60MM NATURE



A S M T A P S

WATER SOUL

EN CONCEALED WASHBASIN MIXER NATURE

FR MITIGEUR LAVABO ENCASTRÉE NATURE

ES MONOMANDO LAVABO EMPOTRAR NATURE

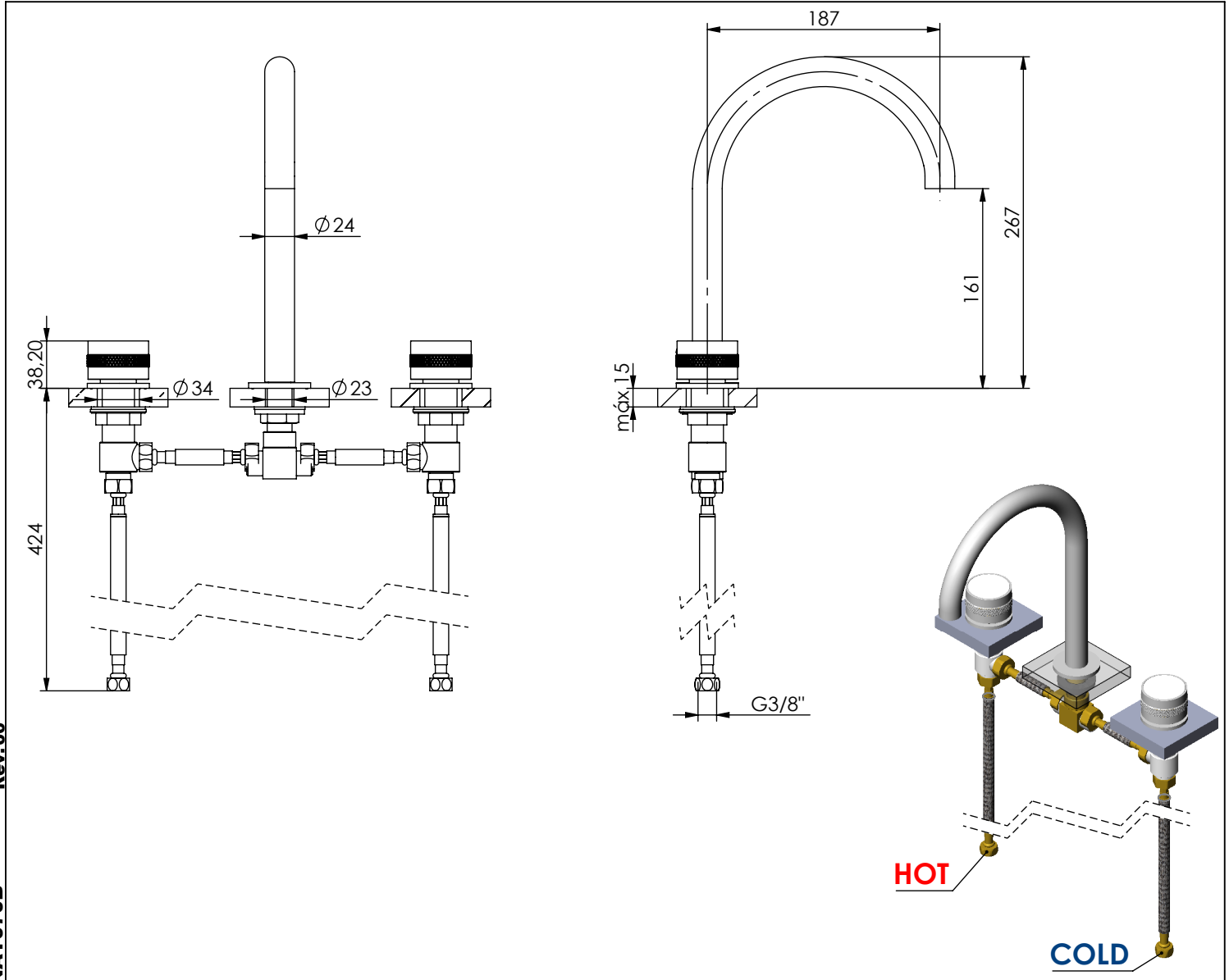

Rev.00

NAT070B

CARACTERÍSTICAS TÉCNICAS

PRESSÃO RECOMENDADA:
RECOMMENDED PRESSURE: 3 - 4 BAR

TEMPERATURA RECOMENDADA:
RECOMMENDED TEMPERATURE: 15°C - 65°C

MATERIAIS:
MATERIALS: Latão

TEMPERATURA MÁXIMA:
MAXIMUM TEMPERATURE: 70°C

CAUDAL MÁXIMO A 3 BAR:
MAXIMUM FLOW AT 3 BAR: 5L/MIN

LIGAÇÃO DE ENTRADA:
INPUT CONNECTION: G1/2"

LIGAÇÃO DE SAÍDA:
OUTPUT CONNECTION: G1/2"

PESO (KG):
WEIGHT (KG): 1,46

DIMENSÕES EMBALAGEM (MM):
SIZE PACKAGING (MM): 274x162x102

ACABAMENTOS

CR - CROMADO | CHROME | CHROME | CROMO

PR - PRETO MATE | BLACK MATT | NOIR MAT | NEGRO MATE

BR - BRANCO MATE | WHITE MATT | BLANC MAT | BLANCO MATE

ST - SATINOX | SATINOX | SATINOX | SATINOX

AT - ANTRACITE | ANTHRACITE | ANTHRACITE | ANTRACITA

GM - GUNMETAL | GUNMETAL | GUNMETAL | GUNMETAL

GMM - GUNMETAL MATE | GUNMETAL MATT | GUNMETAL MAT | GUNMETAL MATE

OR - DOURADO | GOLD | DORÉ | DORADO

ORM - DOURADO MATE | GOLD MATT | DORÉ MAT | DORADO MATE

CB - COBRE | COPPER | CUIVRE | COBRE

CBM - COBRE MAT | COPPER MAT | CUIVRE MAT | COBRE MATE

TECNOLOGIA

-  AC540A - Cartucho Ø35
AC540A - Cartridge Ø35
-  Embutido a parede
Built-in to wall
-  Perlator Embutido
Built-in Aerator