



NAT090C

**MONOCOMANDO EMBUTIR 2/3 VIAS C/
CHUVEIRO MÃO NATURE**



A S M T A P S

W A T E R S O U L

EN CONCEALED 2/3 WAY MIXER WITH SET Ø
HAND SHOWER NATURE

FR CONCEALED 2/3 WAY MIXER WITH SET Ø
HAND SHOWER NATURE

ES CONCEALED 2/3 WAY MIXER WITH SET Ø
HAND SHOWER NATURE

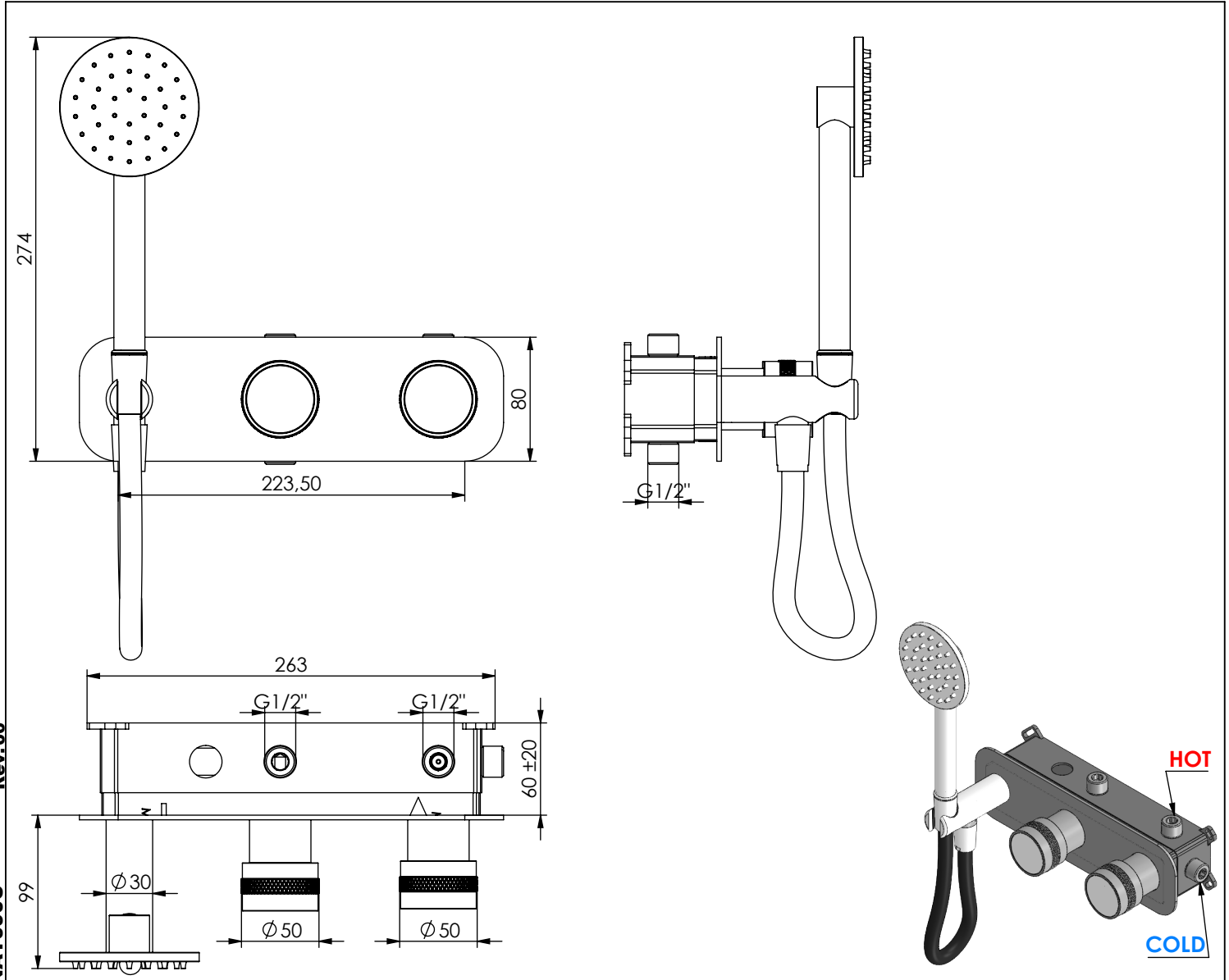

CARACTERÍSTICAS TÉCNICAS

PRESSÃO RECOMENDADA:
RECOMMENDED PRESSURE: 3 - 4 BAR

TEMPERATURA RECOMENDADA:
RECOMMENDED TEMPERATURE: 15°C - 65°C

MATERIAIS:
MATERIALS: Latão

TEMPERATURA MÁXIMA:
MAXIMUM TEMPERATURE: 70°C

CAUDAL MÁXIMO A 3 BAR:
MAXIMUM FLOW AT 3 BAR: L/MIN

LIGAÇÃO DE ENTRADA:
INPUT CONNECTION: G1/2"

LIGAÇÃO DE SAÍDA:
OUTPUT CONNECTION: G1/2"

PESO (KG):
WEIGHT (KG): 3,38

DIMENSÕES EMBALAGEM (MM):
SIZE PACKAGING (MM): 285x200x170

ACABAMENTOS

CR - CROMADO | CHROME | CHROME | CROMO

PR - PRETO MATE | BLACK MATT | NOIR MAT | NEGRO MATE

BR - BRANCO MATE | WHITE MATT | BLANC MAT | BLANCO MATE

ST - SATINOX | SATINOX | SATINOX | SATINOX

AT - ANTRACITE | ANTHRACITE | ANTHRACITE | ANTRACITA

GM - GUNMETAL | GUNMETAL | GUNMETAL | GUNMETAL

GMM - GUNMETAL MATE | GUNMETAL MATT | GUNMETAL MAT | GUNMETAL MATE

OR - DOURADO | GOLD | DORÉ | DORADO

ORM - DOURADO MATE | GOLD MATT | DORÉ MAT | DORADO MATE

CB - COBRE | COPPER | CUIVRE | COBRE

CBM - COBRE MAT | COPPER MAT | CUIVRE MAT | COBRE MATE

TECNOLOGIA

-  AC560 - DISTRIBUIDOR 3/4 VIAS
AC560 - 3/4 WAY DISTRIBUTOR
-  AC1340 - Cartucho Ø35 Progressivo
AC1340 - Ø35 Progressive Cartridge
-  Chuveiro de mão cilíndrico Latão
Brass cylindrical hand shower
-  Ligação banheira/duche 1,70mt silicone
Bath/shower connection 1.70 mt silicone
-  Embutido a parede
Built-in to wall

! SERVICE

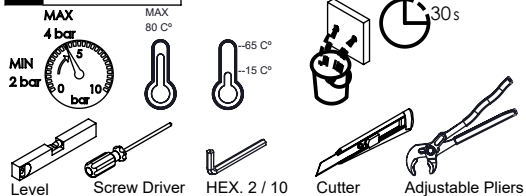

NAT090C

MONOCOMANDO EMBUTIR 2/3 VIAS
C/ CHUVEIRO MÃO NATURE



A S M T A P S ®

W A T E R S O U L

INSTALLATION MANUAL

1 CONECTION

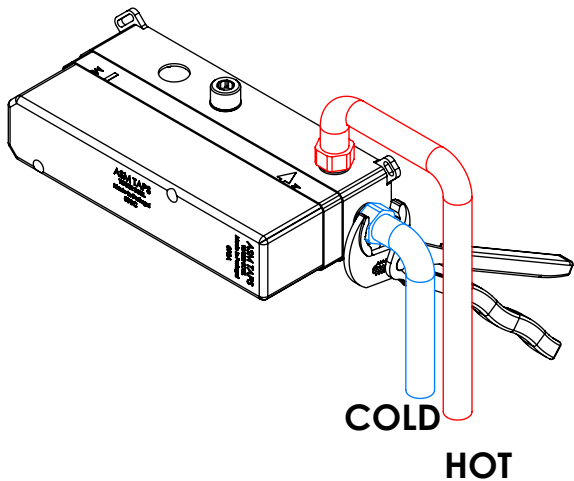

2 FIXED

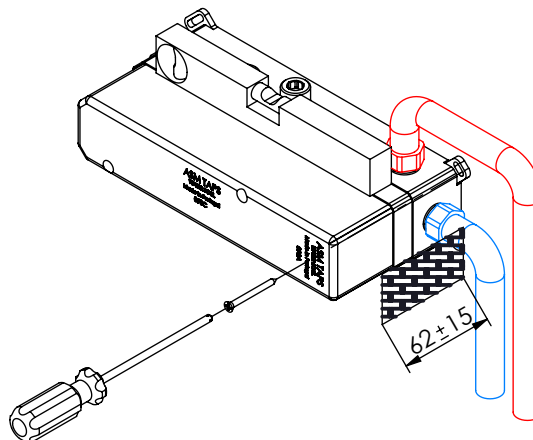

3 REMOVE PROTECTION

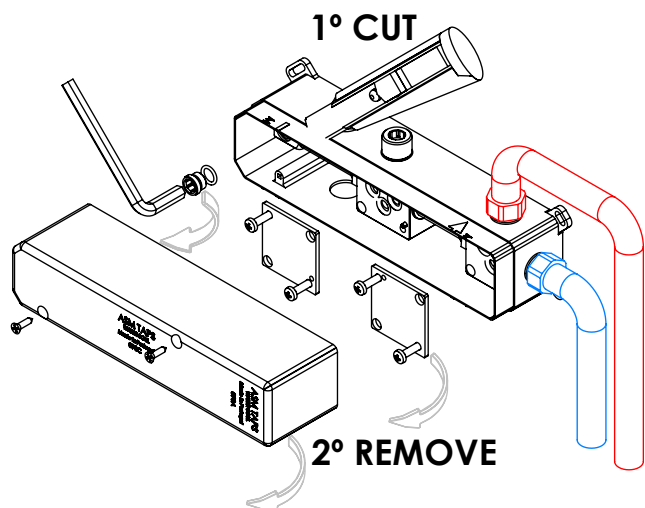

4 FIX IT

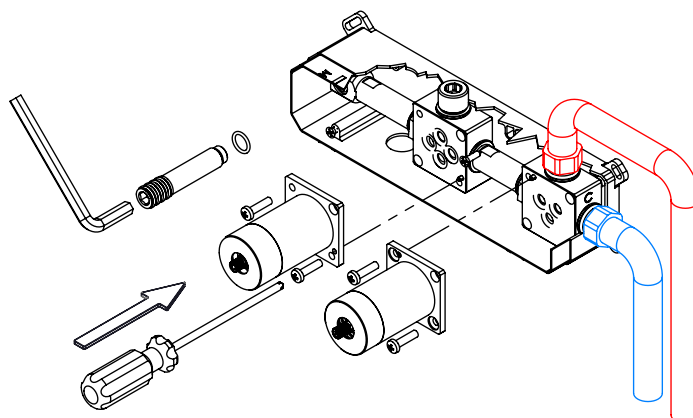

5 FIX IT

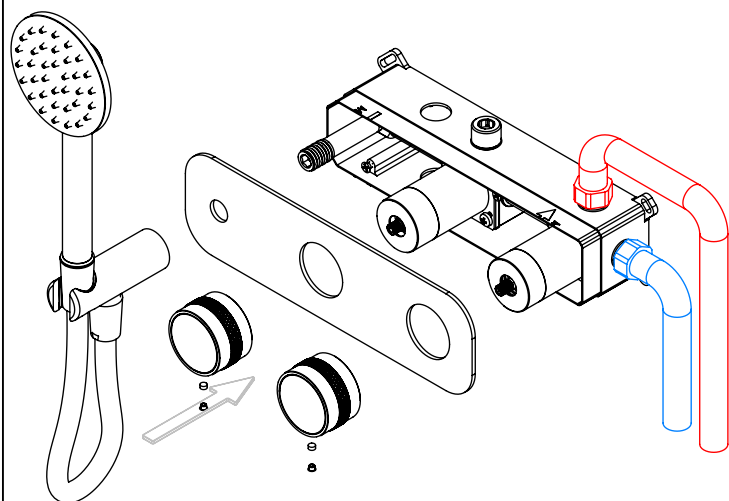

6 MAINTENANCE

