



PLAN080

MONOCOMANDO EMBUTIR BANHO/DUCHE 2 VIAS PLAN



A S M T A P S®

WATER SOUL

EN CONCEALED 2 WAY BATH/SHOWER MIXER PLAN

FR MITIGEUR BAIGNOIRE/DOUCHE ENCASTRÉ 2 VOIES PLAN

ES MONOMANDO BAÑO/DUCHA EMPOTRAR 2 VIAS PLAN

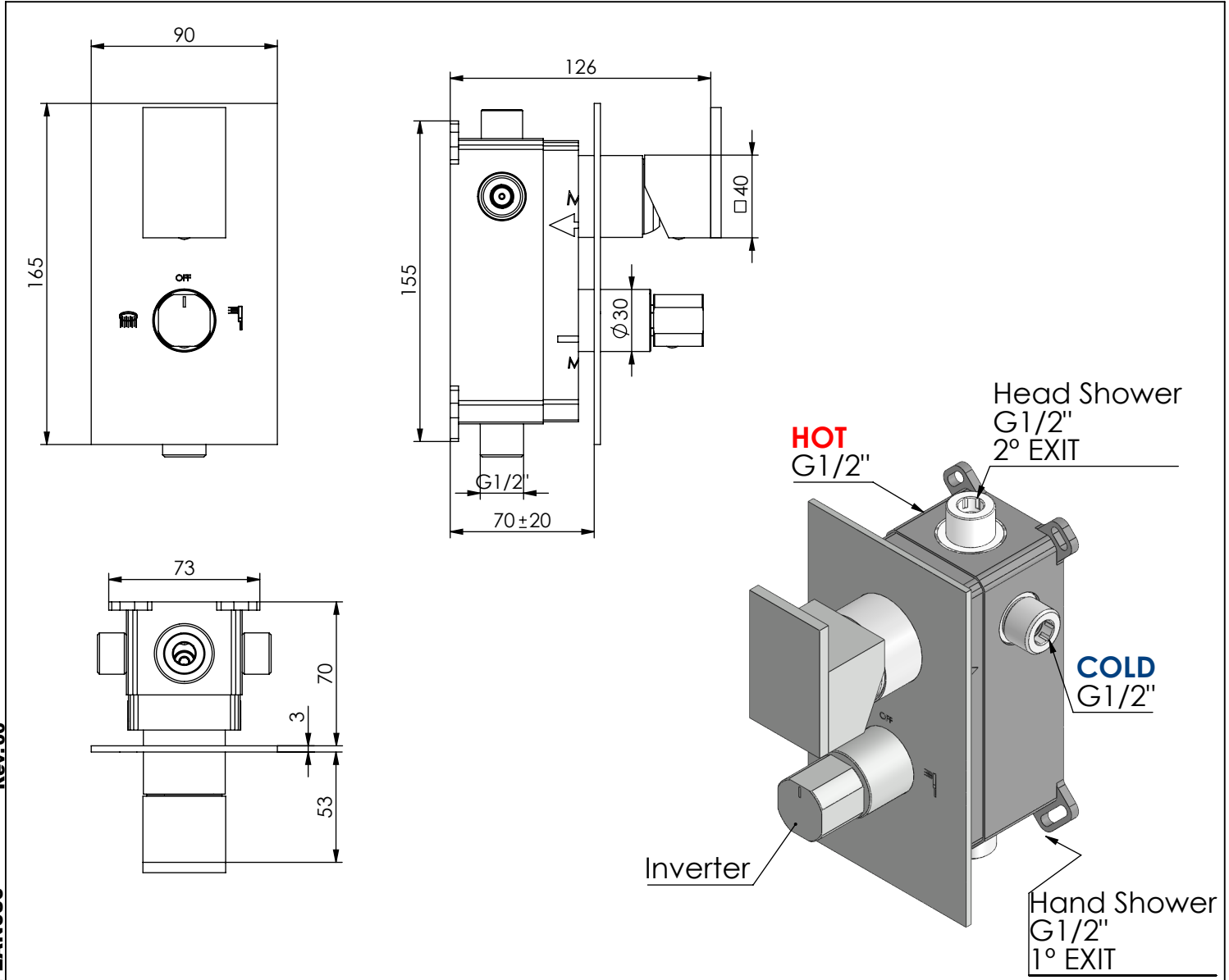

Rev.00

PLAN080

CARACTERÍSTICAS TÉCNICAS

PRESSÃO RECOMENDADA: RECOMMENDED PRESSURE:	3 - 4 BAR
TEMPERATURA RECOMENDADA: RECOMMENDED TEMPERATURE:	15°C - 65°C
MATERIAIS: MATERIALS:	Latão
TEMPERATURA MÁXIMA: MAXIMUM TEMPERATURE:	70°C
CAUDAL MÁXIMO A 3 BAR: MAXIMUM FLOW AT 3 BAR:	L/MIN
LIGAÇÃO DE ENTRADA: INPUT CONNECTION:	G1/2"
LIGAÇÃO DE SAÍDA: OUTPUT CONNECTION:	G1/2"
PESO (KG): WEIGHT (KG):	2,27
DIMENSÕES EMBALAGEM (MM): SIZE PACKAGING (MM):	274x162x102

ACABAMENTOS

CR - CROMADO CHROME CHROME CROMO
PR - PRETO MATE BLACK MATT NOIR MAT NEGRO MATE
BR - BRANCO MATE WHITE MATT BLANC MAT BLANCO MATE
ST - SATINOX SATINOX SATINOX SATINOX
AT - ANTRACITE ANTHRACITE ANTHRACITE ANTRACITA
GM - GUNMETAL GUNMETAL GUNMETAL GUNMETAL
GMM - GUNMETAL MATE GUNMETAL MATT GUNMETAL MAT GUNMETAL MATE
OR - DOURADO GOLD DORÉ DORADO
ORM - DOURADO MATE GOLD MATT DORÉ MAT DORADO MATE
CB - COBRE COPPER CUIVRE COBRE
CBM - COBRE MAT COPPER MAT CUIVRE MAT COBRE MATE

TECNOLOGIA

	AC540A - Cartucho Ø35 AC540A - Cartridge Ø35
	AC1840 - Distribuidor 2 vias Ø25 AC1840 - 2 way distributor Ø25
	Embutido a parede Built-in to wall

! SERVICE

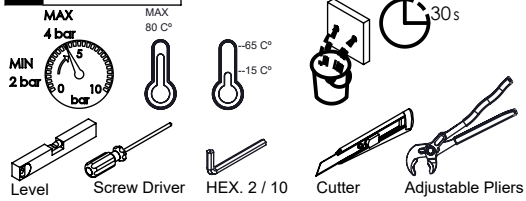

PLAN080

MONOCOMANDO EMBUTIR BANHO/DUCHE 2 VIAS PLAN



A S M T A P S ®

W A T E R S O U L

INSTALLATION MANUAL

1 CONECTION

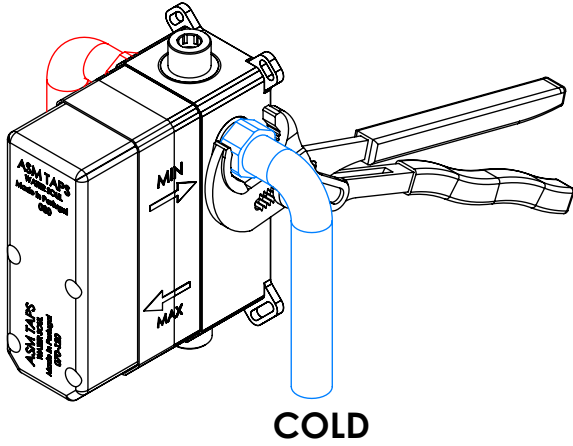

2 FIXED

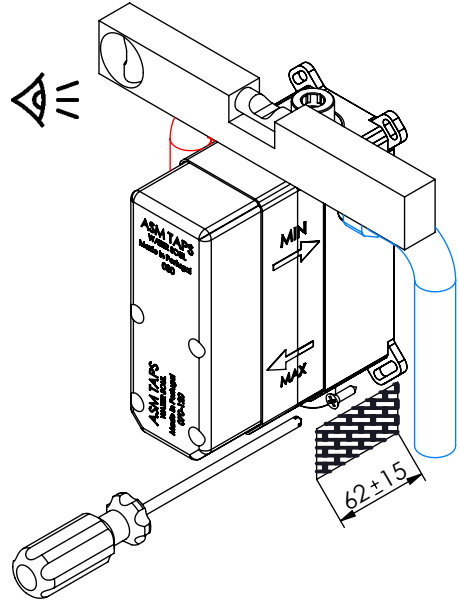

3 REMOVE PROTECTION

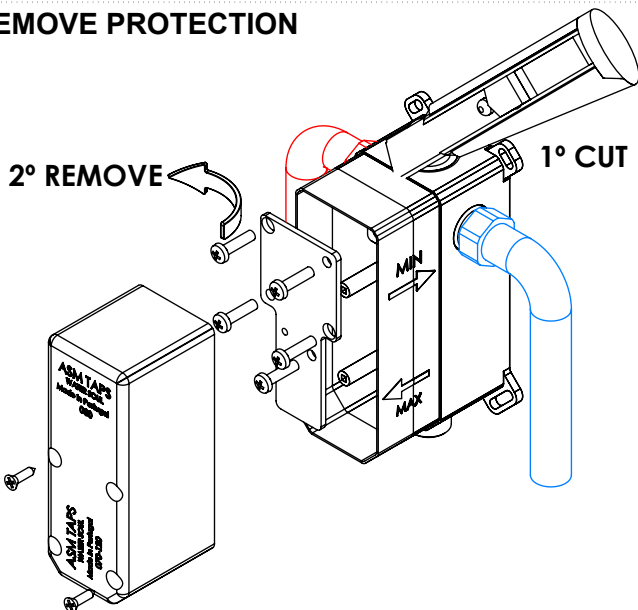

4 FIX IT

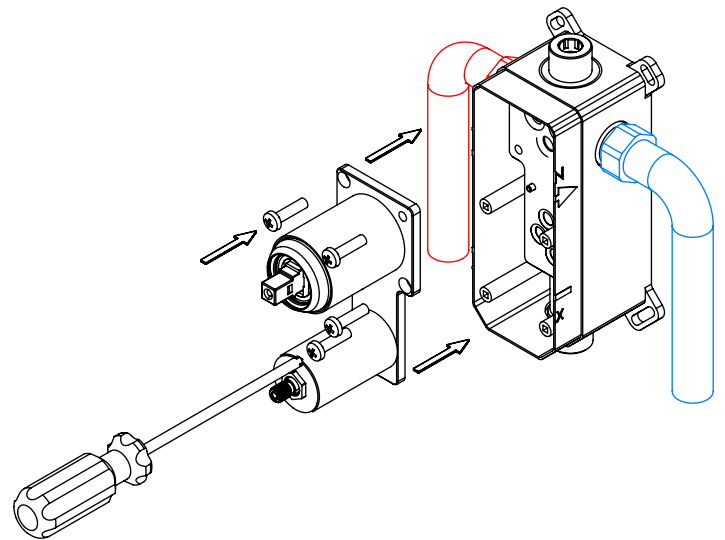

5 FIX IT

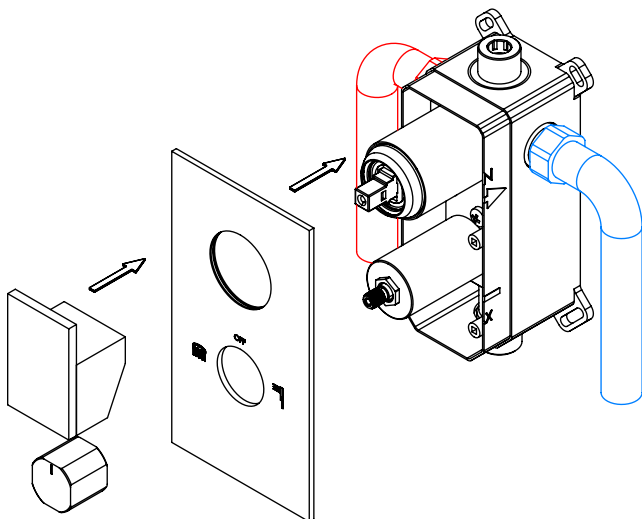

6 MAINTENANCE

