

SPIRAL070C

MONOC. EMBUTIR LAVAT. PAREDE
ESPELHO REDONDOS 60MM SPIRAL



ASM TAPS®

WATER SOUL

EN CONCEALED WASHBASIN MIXER SPIRAL

FR MITIGEUR LAVABO ENCASTRÉE SPIRAL

ES MONOMANDO LAVABO EMPOTRAR SPIRAL

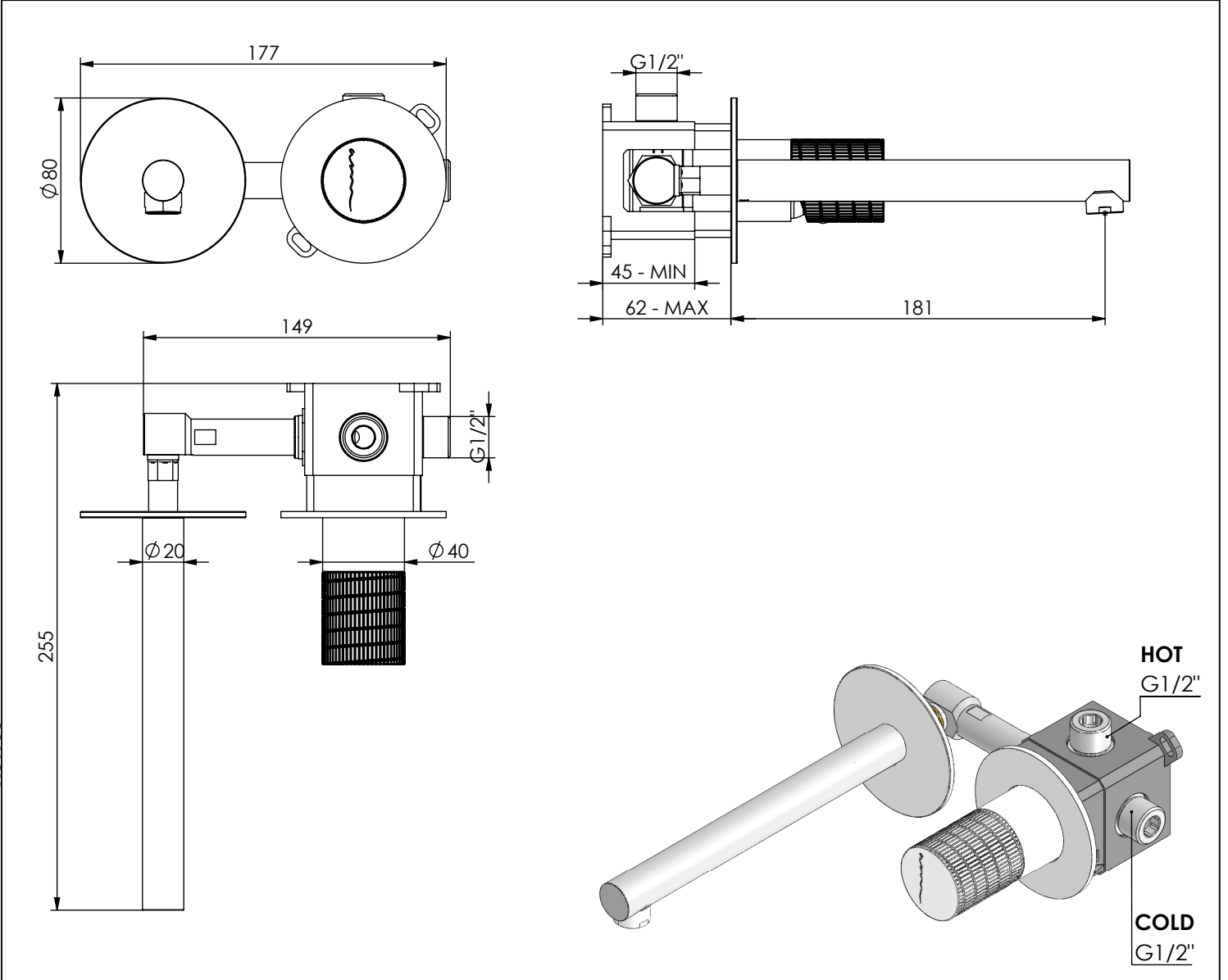
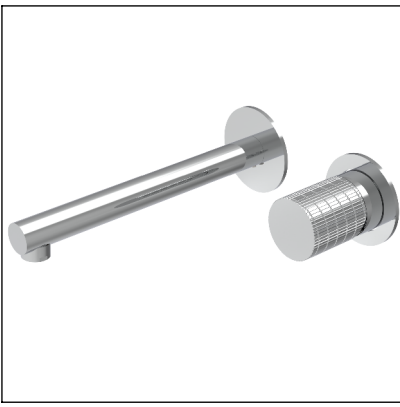

SPIRAL070C Rev.00



CARACTERÍSTICAS TÉCNICAS

PRESSÃO RECOMENDADA: RECOMMENDED PRESSURE:	3 - 4 BAR
TEMPERATURA RECOMENDADA: RECOMMENDED TEMPERATURE:	15°C - 65°C
MATERIAIS: MATERIALS:	Latão
TEMPERATURA MÁXIMA: MAXIMUM TEMPERATURE:	70°C
CAUDAL MÁXIMO A 3 BAR: MAXIMUM FLOW AT 3 BAR:	5L/MIN
LIGAÇÃO DE ENTRADA: INPUT CONNECTION:	G1/2"
LIGAÇÃO DE SAÍDA: OUTPUT CONNECTION:	G1/2"
PESO (KG): WEIGHT (KG):	1,455
DIMENSÕES EMBALAGEM (MM): SIZE PACKAGING (MM):	274x162x102

ACABAMENTOS

CR - CROMADO CHROME CHROME CROMO
PR - PRETO MATE BLACK MATT NOIR MAT NEGRO MATE
BR - BRANCO MATE WHITE MATT BLANC MAT BLANCO MATE
ST - SATINOX SATINOX SATINOX SATINOX
AT - ANTRACITE ANTHRACITE ANTHRACITE ANTRACITA
GM - GUNMETAL GUNMETAL GUNMETAL GUNMETAL
GMM - GUNMETAL MATE GUNMETAL MATT GUNMETAL MAT GUNMETAL MATE
OR - DOURADO GOLD DORÉ DORADO
ORM - DOURADO MATE GOLD MATT DORÉ MAT DORADO MATE
CB - COBRE COPPER CUIVRE COBRE
CBM - COBRE MAT COPPER MAT CUIVRE MAT COBRE MATE

TECNOLOGIA

-  AC540C - Cartucho Ø35 Energy Saving
AC540C - Ø35 Energy Saving Cartridge
-  Embutido a parede
Built-in to wall
-  Abertura energia saving
Opening energy saving

! SERVICE

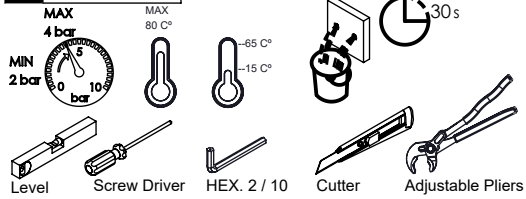

SPIRAL070C

MONOC. EMBUTIR LAVAT. PAREDE
ESPELHO REDONDOS 60MM SPIRAL



A S M T A P S ®

W A T E R S O U L

INSTALLATION MANUAL

1 CONECTION

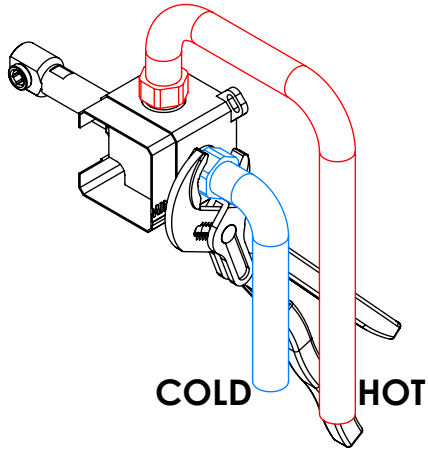

2 FIXED

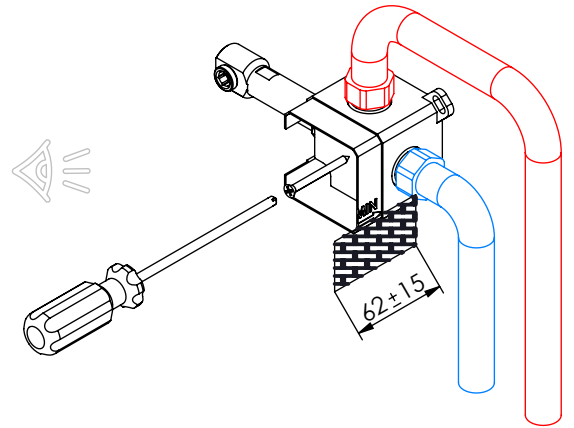

3 REMOVE PROTECTION

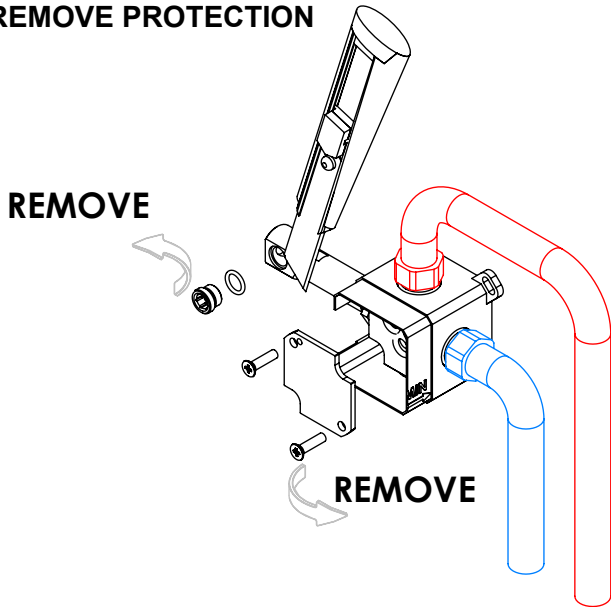

4 FIX IT

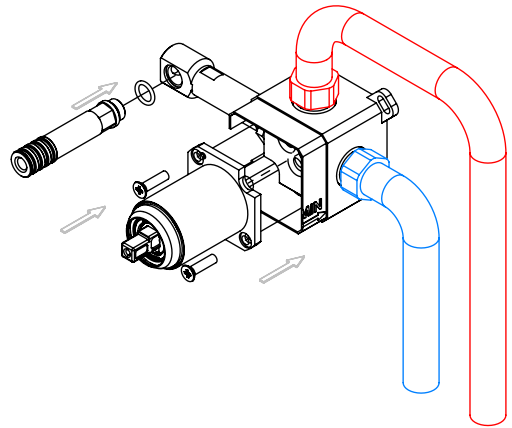

5 FIX IT

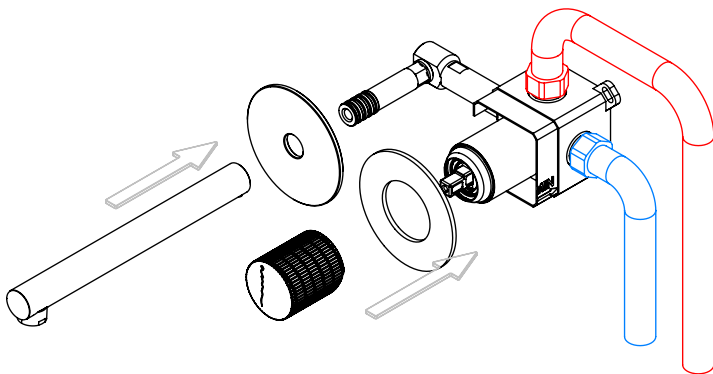

6 MAINTENANCE

