



SPIRAL150

MONOCOMANDO LAVATÓRIO MONTAGEM AO CHÃO SPIRAL

EN WASHBASIN MIXER FLOOR MOUNTED SPIRAL

FR MITIGEUR LAVABO AU SOL SPIRAL

ES MONOMANDO LAVABO AL SUELO SPIRAL



A S M T A P S

WATER SOUL

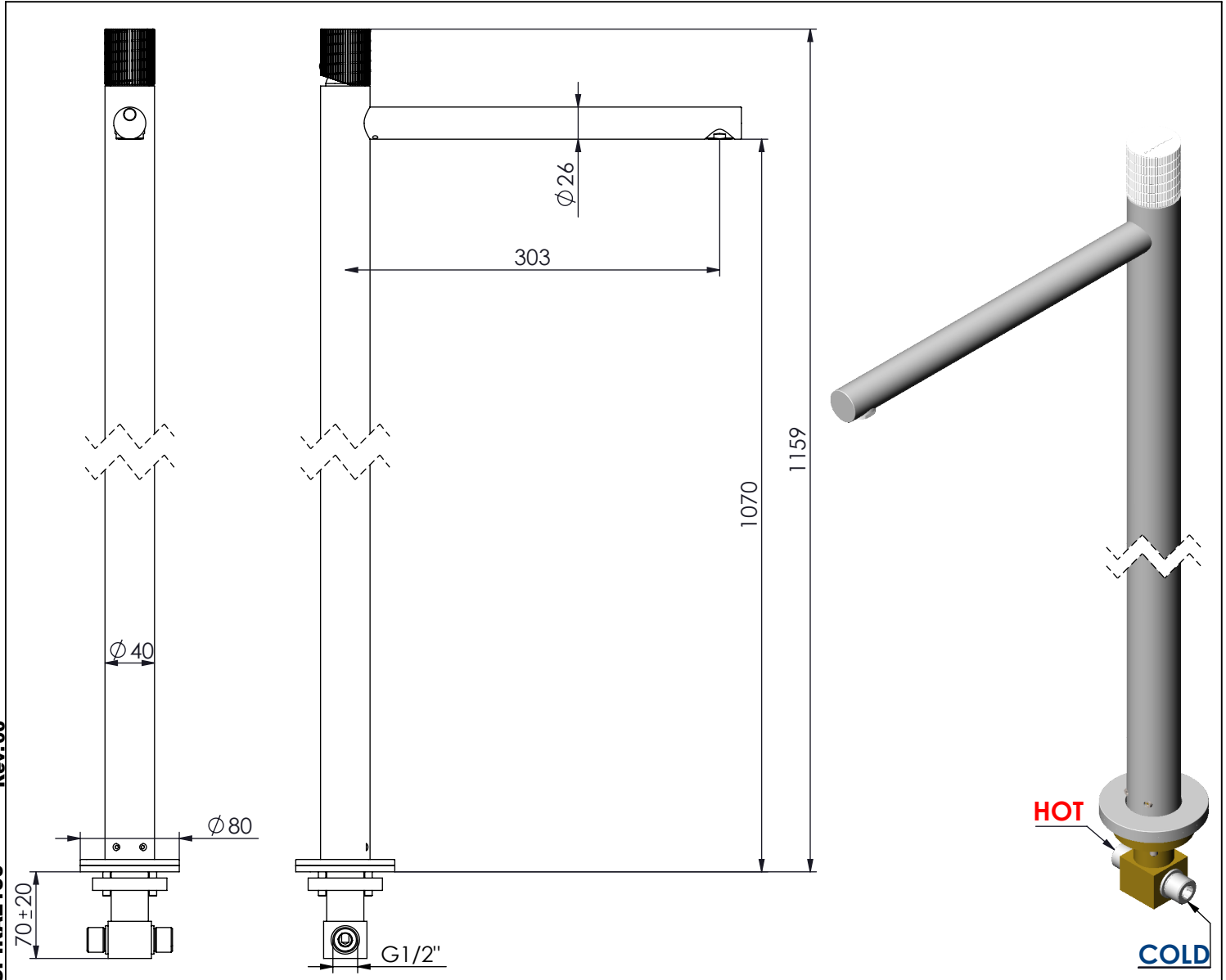

SPIRAL150 Rev.00

CARACTERÍSTICAS TÉCNICAS

PRESSÃO RECOMENDADA: RECOMMENDED PRESSURE:	3 - 4 BAR
TEMPERATURA RECOMENDADA: RECOMMENDED TEMPERATURE:	15°C - 65°C
MATERIAIS: MATERIALS:	Latão
TEMPERATURA MÁXIMA: MAXIMUM TEMPERATURE:	70°C
CAUDAL MÁXIMO A 3 BAR: MAXIMUM FLOW AT 3 BAR:	5L/MIN
LIGAÇÃO DE ENTRADA: INPUT CONNECTION:	G1/2"
LIGAÇÃO DE SAÍDA: OUTPUT CONNECTION:	.
PESO (KG): WEIGHT (KG):	6
DIMENSÕES EMBALAGEM (MM): SIZE PACKAGING (MM):	1110x452x92

ACABAMENTOS

CR - CROMADO CHROME CHROME CROMO
PR - PRETO MATE BLACK MATT NOIR MAT NEGRO MATE
BR - BRANCO MATE WHITE MATT BLANC MAT BLANCO MATE
ST - SATINOX SATINOX SATINOX SATINOX
AT - ANTRACITE ANTHRACITE ANTHRACITE ANTRACITA
GM - GUNMETAL GUNMETAL GUNMETAL GUNMETAL
GMM - GUNMETAL MATE GUNMETAL MATT GUNMETAL MAT GUNMETAL MATE
OR - DOURADO GOLD DORÉ DORADO
ORM - DOURADO MATE GOLD MATT DORÉ MAT DORADO MATE
CB - COBRE COPPER CUIVRE COBRE
CBM - COBRE MAT COPPER MAT CUIVRE MAT COBRE MATE

TECNOLOGIA

Embutido Ao chão
Built-in to ground

! SERVICE

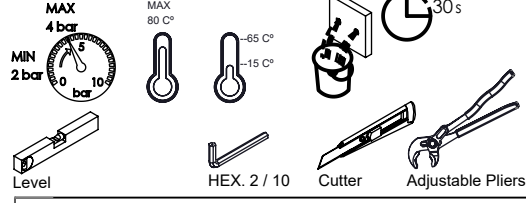

SPIRAL150

MONOCOMANDO LAVATÓRIO

MONTAGEM AO CHÃO SPIRAL



A S M T A P S ®

W A T E R S O U L

INSTALLATION MANUAL

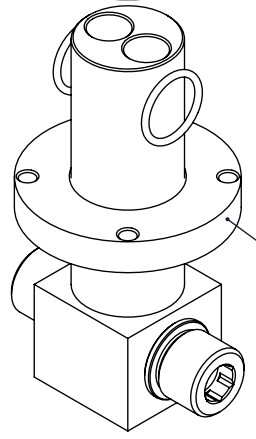
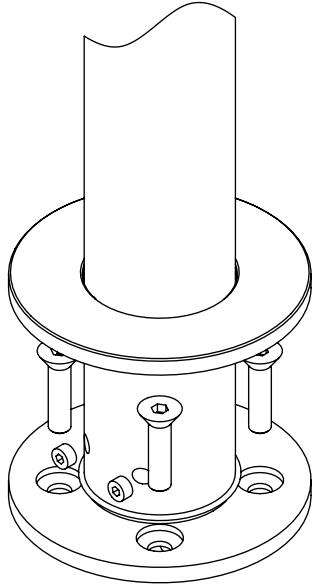

Atenção:
Rodar para baixo (5mm)
à Superfície

Superfície

