



TERCTIME080

MISTURADORA EMBUTIR TERMOSTATICA 2 VIAS TIMELESS



A S M T A P S

WATER SOUL

EN CONCEALED 2 WAY THERMOSTATIC MIXER TIMELESS

FR MÉLANGEUR ENCASTRÉ 2 VOIES THERMOSTATIQUE TIMELESS

ES MEZCLADOR EMPOTRAR 2 VIAS TERMOSTÁTICO TIMELESS

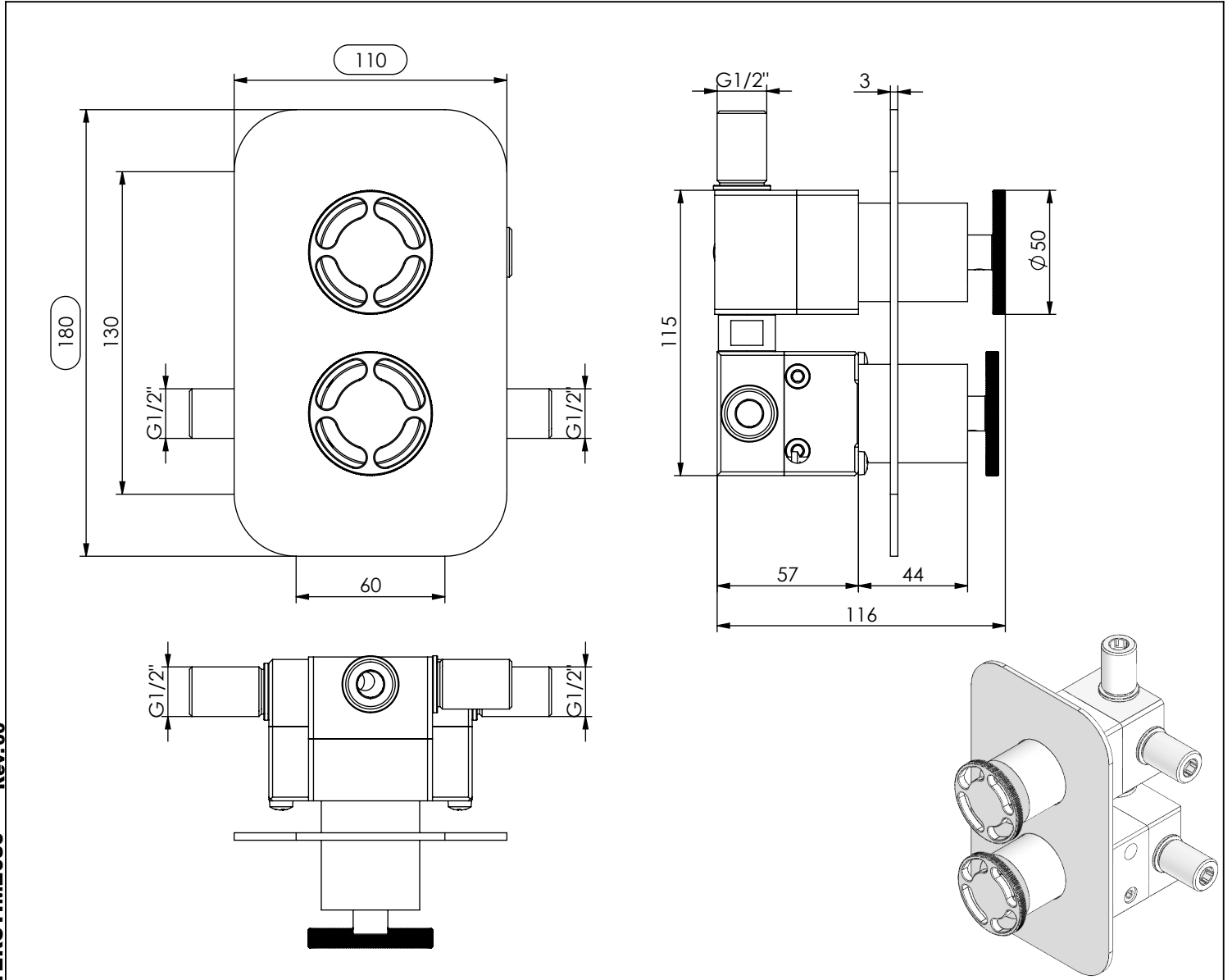

TERCTIME080 Rev.00

CARACTERÍSTICAS TÉCNICAS

PRESSÃO RECOMENDADA:
RECOMMENDED PRESSURE: 3 - 4 BAR

TEMPERATURA RECOMENDADA:
RECOMMENDED TEMPERATURE: 15°C - 65°C

MATERIAIS:
MATERIALS: Latão

TEMPERATURA MÁXIMA:
MAXIMUM TEMPERATURE: 70°C

CAUDAL MÁXIMO A 3 BAR:
MAXIMUM FLOW AT 3 BAR: L/MIN

LIGAÇÃO DE ENTRADA:
INPUT CONNECTION: G1/2"

LIGAÇÃO DE SAÍDA:
OUTPUT CONNECTION: G1/2"

PESO (KG):
WEIGHT (KG): NC

DIMENSÕES EMBALAGEM (MM):
SIZE PACKAGING (MM): 285x200x170

ACABAMENTOS

CR - CROMADO | CHROME | CHROME | CROMO

PR - PRETO MATE | BLACK MATT | NOIR MAT | NEGRO MATE

BR - BRANCO MATE | WHITE MATT | BLANC MAT | BLANCO MATE

ST - SATINOX | SATINOX | SATINOX | SATINOX

AT - ANTRACITE | ANTHRACITE | ANTHRACITE | ANTRACITA

GM - GUNMETAL | GUNMETAL | GUNMETAL | GUNMETAL

GMM - GUNMETAL MATE | GUNMETAL MATT | GUNMETAL MAT | GUNMETAL MATE





OR - DOURADO | GOLD | DORÉ | DORADO

ORM - DOURADO MATE | GOLD MATT | DORÉ MAT | DORADO MATE

CB - COBRE | COPPER | CUIVRE | COBRE

CBM - COBRE MAT | COPPER MAT | CUIVRE MAT | COBRE MATE

TECNOLOGIA

-  AC1180-Distribuidor Misturadora Termostática
AC1180-Distributor Thermostatic Mixer
-  AC1940 - Cartucho termostático Mini Kerox
AC1940 - Mini Thermostatic Cartridge Kerox
-  Embutido a parede
Built-in to wall
-  Termostática
Thermostatic

! SERVICE

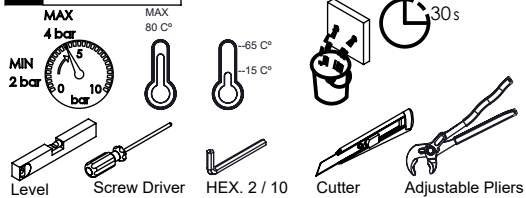

TERCTIME080

MISTURADORA EMBUTIR
TERMOSTATICA 2 VIAS TIMELESS



A S M T A P S[®]

W A T E R S O U L

INSTALLATION MANUAL

1 CONECTION

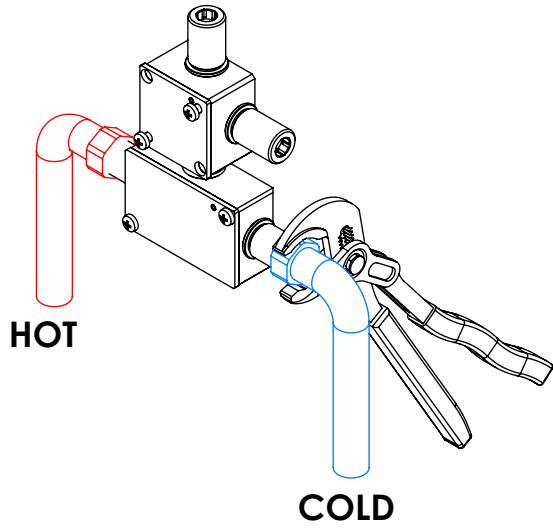

2 FIXED

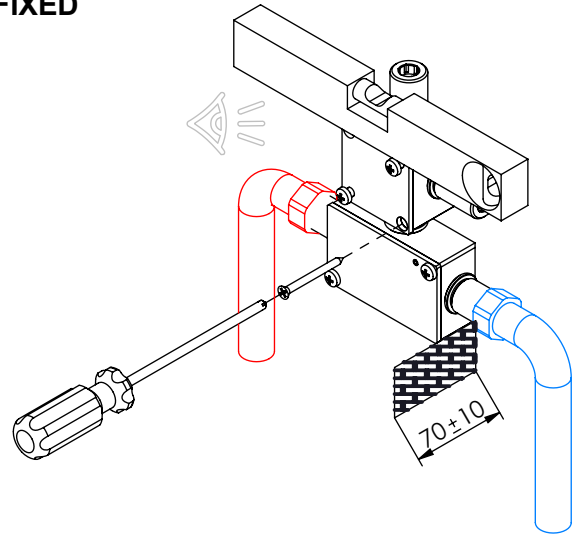

3 REMOVE PROTECTION

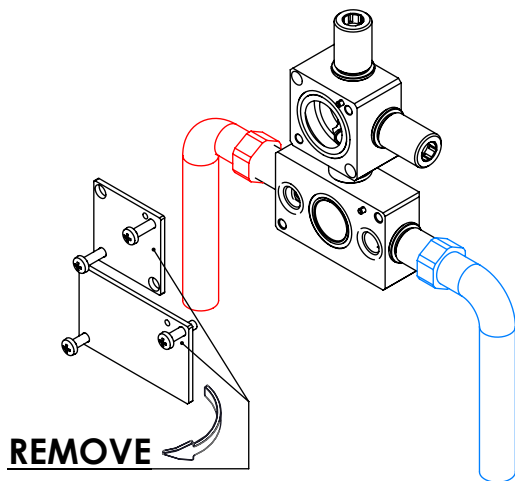

4 FIX IT

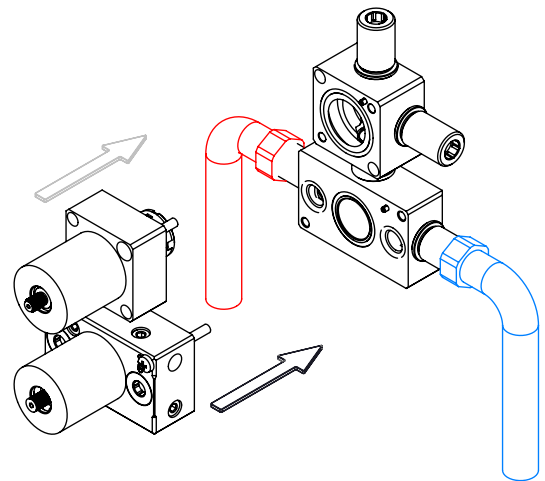

5 FIX IT

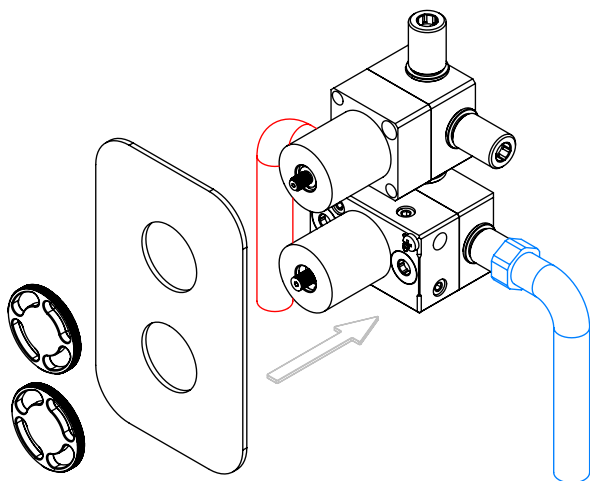

6 MAINTENANCE

