



TIME020

MISTURADORA BIDÉ TIMELESS



ASM TAPS®

WATER SOUL

EN BIDET MIXER TIMELESS

FR MÉLANGEUR BIDET TIMELESS

ES MEZCLADOR BIDÉ TIMELESS

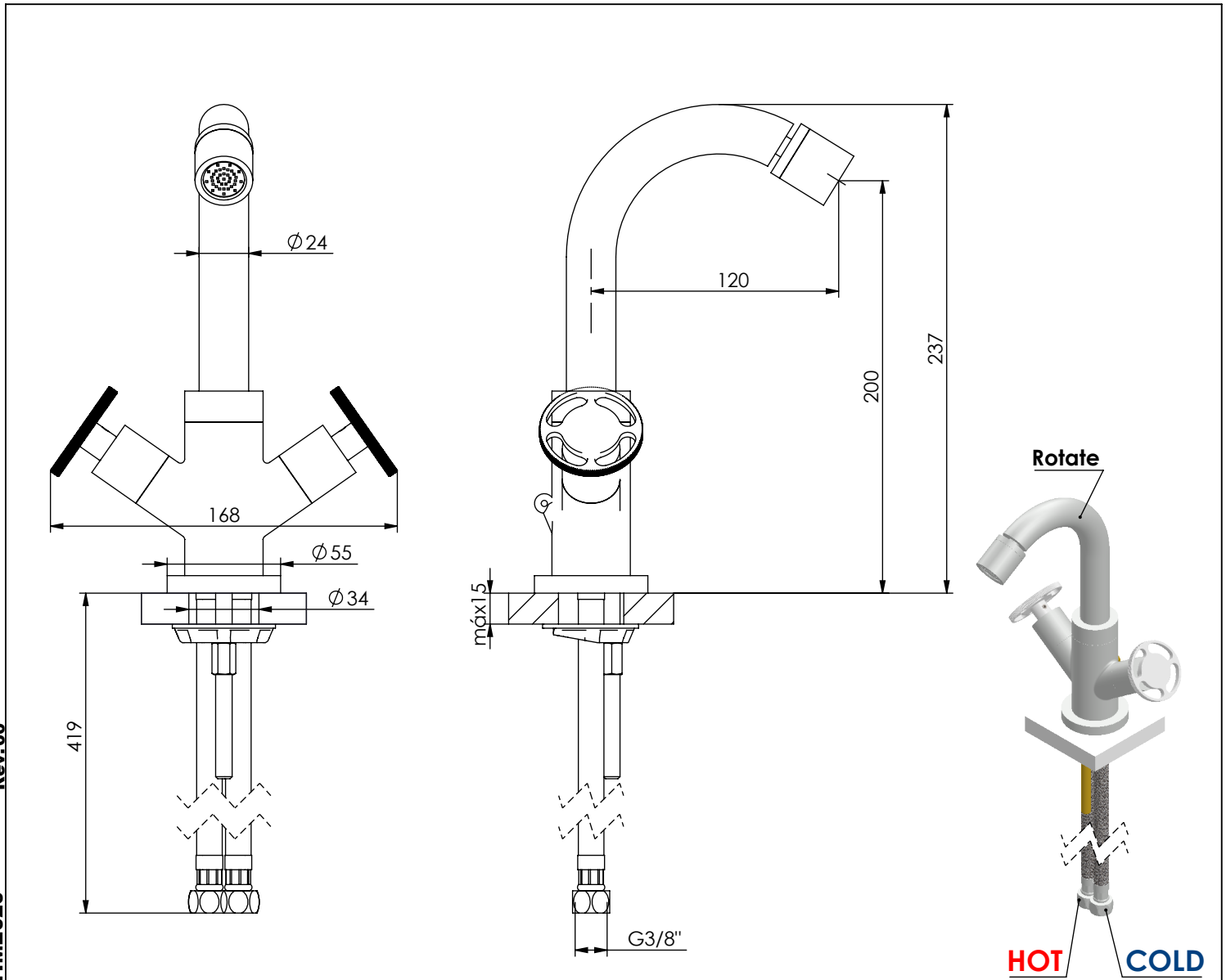

TIME020 Rev.00

CARACTERÍSTICAS TÉCNICAS

PRESSÃO RECOMENDADA: RECOMMENDED PRESSURE:	3 - 4 BAR
TEMPERATURA RECOMENDADA: RECOMMENDED TEMPERATURE:	15°C - 65°C
MATERIAIS: MATERIALS:	Latão
TEMPERATURA MÁXIMA: MAXIMUM TEMPERATURE:	70°C
CAUDAL MÁXIMO A 3 BAR: MAXIMUM FLOW AT 3 BAR:	L/MIN
LIGAÇÃO DE ENTRADA: INPUT CONNECTION:	G3/8"
LIGAÇÃO DE SAÍDA: OUTPUT CONNECTION:	-
PESO (KG): WEIGHT (KG):	1,46
DIMENSÕES EMBALAGEM (MM): SIZE PACKAGING (MM):	365x250x80

ACABAMENTOS

CR - CROMADO CHROME CHROME CROMO
PR - PRETO MATE BLACK MATT NOIR MAT NEGRO MATE
BR - BRANCO MATE WHITE MATT BLANC MAT BLANCO MATE
ST - SATINOX SATINOX SATINOX SATINOX
AT - ANTRACITE ANTHRACITE ANTHRACITE ANTRACITA
GM - GUNMETAL GUNMETAL GUNMETAL GUNMETAL
GMM - GUNMETAL MATE GUNMETAL MATT GUNMETAL MAT GUNMETAL MATE
OR - DOURADO GOLD DORÉ DORADO
ORM - DOURADO MATE GOLD MATT DORÉ MAT DORADO MATE
CB - COBRE COPPER CUIVRE COBRE
CBM - COBRE MAT COPPER MAT CUIVRE MAT COBRE MATE

TECNOLOGIA

 AC1360 - CASTELO CERÁMICO 1/2" 1/4 VOLTA
AC1360 - CERAMIC VALVE 1/2" 1/4 TURN